

Drywall ceiling canopy

Canopy techo tablaroca

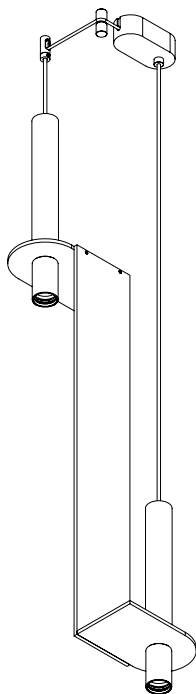

Meta Parallel 143

Material care

Recinto or fiorito - Use a soft rag, a clean white cloth, or vacuum with a soft brush attachment as needed, do not wipe wet.

Powder coated Aluminum - Dust gently with a duster or soft rag. Do not use commercial cleaners.
Avoid abrasive cleaning agents.

Polished brass - The hand polished solid brass will naturally oxidate and reflect the language of time. Upon touching the items without gloves, fingerprints are likely to occur and leave marks. Use a good quality brass cleaning liquid in order to remove any marks from the brass. Please note that you will also lose the age brass look. Do not apply pressure to avoid any scratches.

Cuidado del material

Recinto o fiorito - Use un trapo suave, un paño blanco limpio o aspire con un accesorio de cepillo suave según sea necesario, no lo limpie en húmedo.

Metal - Retire el polvo suavemente con un plumero o un trapo suave y seco. No utilice limpiadores comerciales. Evite los agentes de limpieza abrasivos.

Latón - El latón sólido pulido, comenzará a tener un lenguaje propio a través del envejecimiento que tendrá.
Por lo que recomendamos usar guantes para evitar marcas no deseadas. Para remover manchas, use un limpiador líquido de metales específicos para latón o plata. Aplíquelo a una microfibrá y frote suavemente

Parts included

Partes incluidas

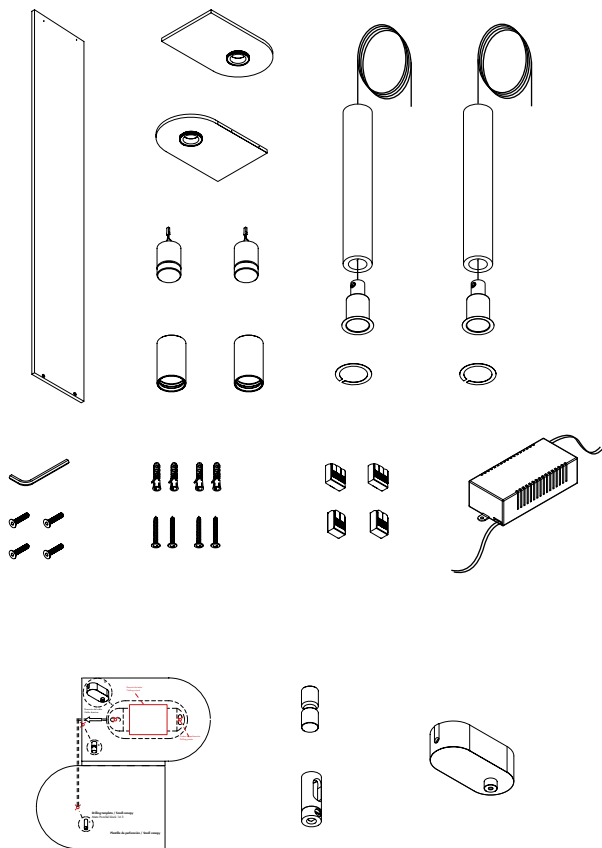

Notes before assembly



We recommend reading the complete assembly manual before starting the installation.

Disconnect the power by turning off the circuit breaker, or by removing the fuse in the fuse box before assembling and mounting.

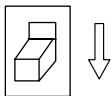

Use gloves provided at any time of the installation



Two people are needed for installation.

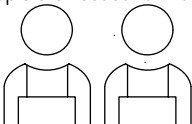

Be careful when unpacking the product to avoid damaging any of the elements. We recommend placing it on a protective surface such as a cardboard or a blanket.

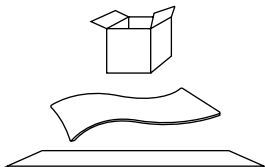

Notas antes del montaje



Recomendamos leer el manual de montaje completo antes de iniciar la instalación.

Desconecte la alimentación bajando la pastilla o quitando el fusible de la caja de fusibles antes de ensamblar y montar.

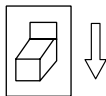

Utilice los guantes proporcionados en cualquier momento de la instalación.



Se necesitan dos personas para la instalación.

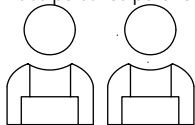

Tenga cuidado al desempacar este producto para no dañar ninguno de los elementos. Recomendamos colocarlo sobre una superficie protectora como un cartón o una manta y el uso de un par de guantes(incluidos)

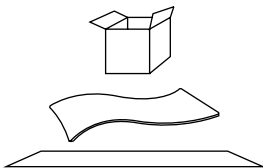



Screw gently but firmly the screw. Take care to insert the screw straight.
Atornille suave pero firme el tornillo. Inserte el tornillo recto en la perforación.

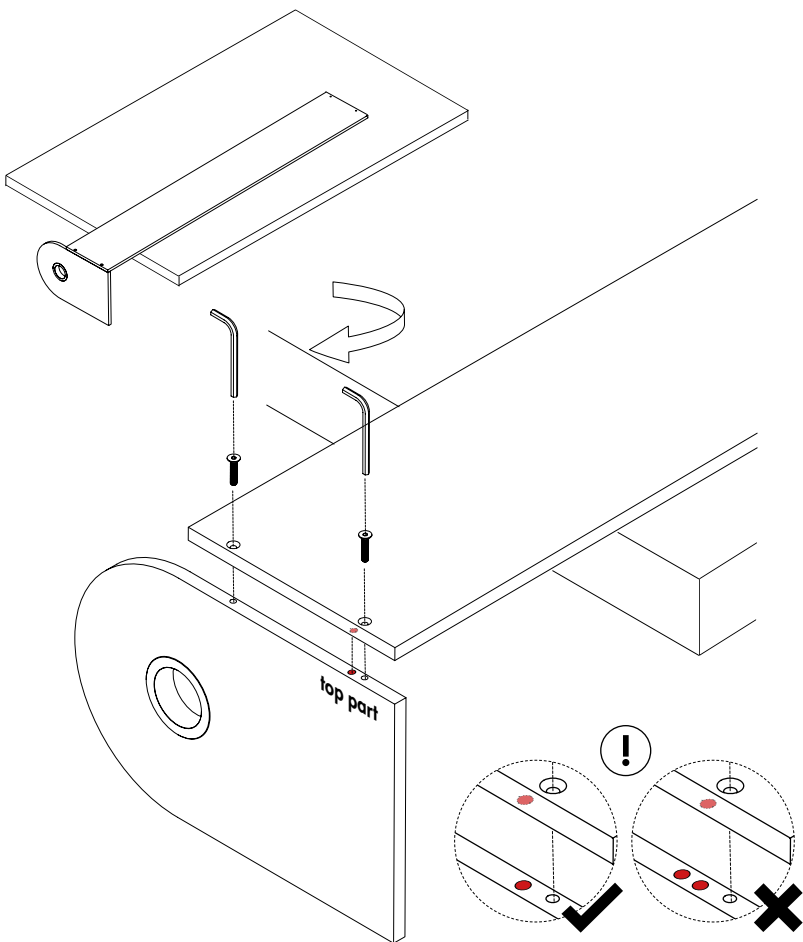

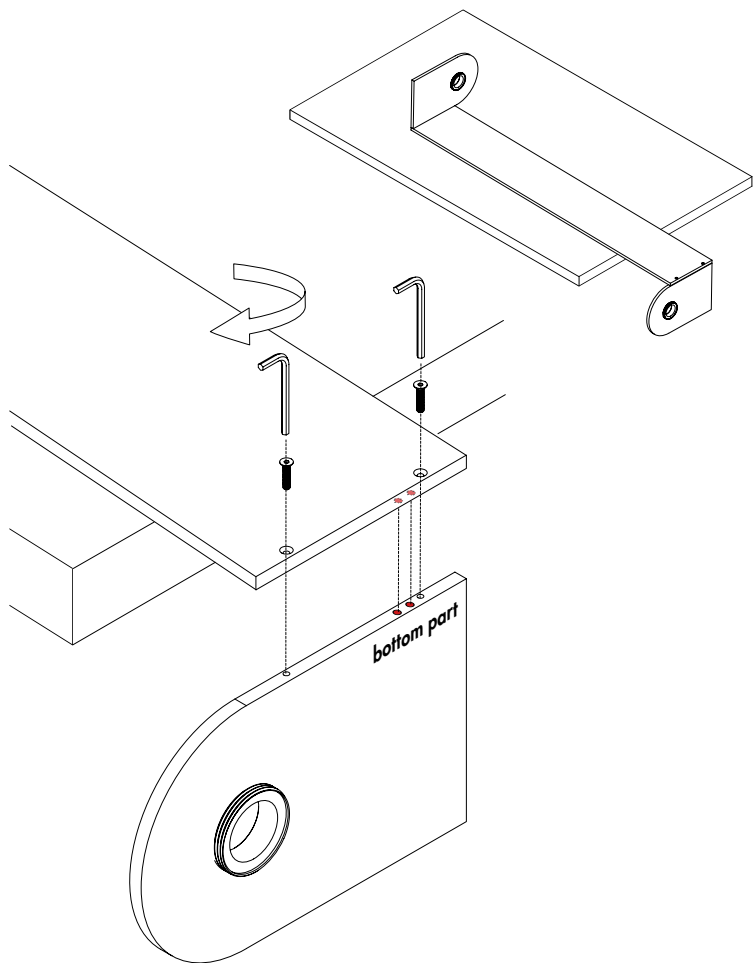



The template needs to be attached flat on the ceiling. Make sure the printed face looks downside.

La plantilla tiene que estar plana al techo. Asegurese que la impresion vea hacia el piso.

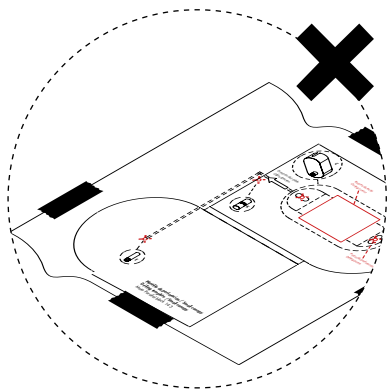
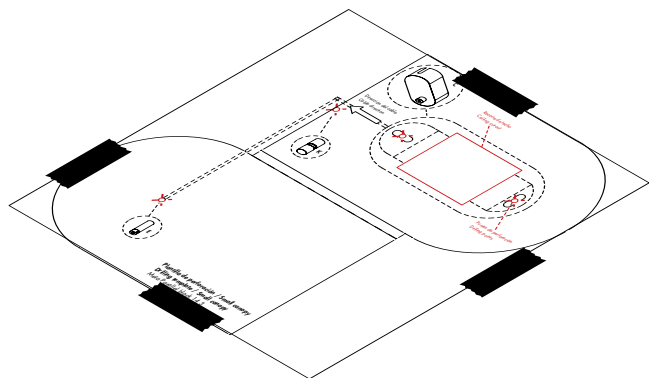

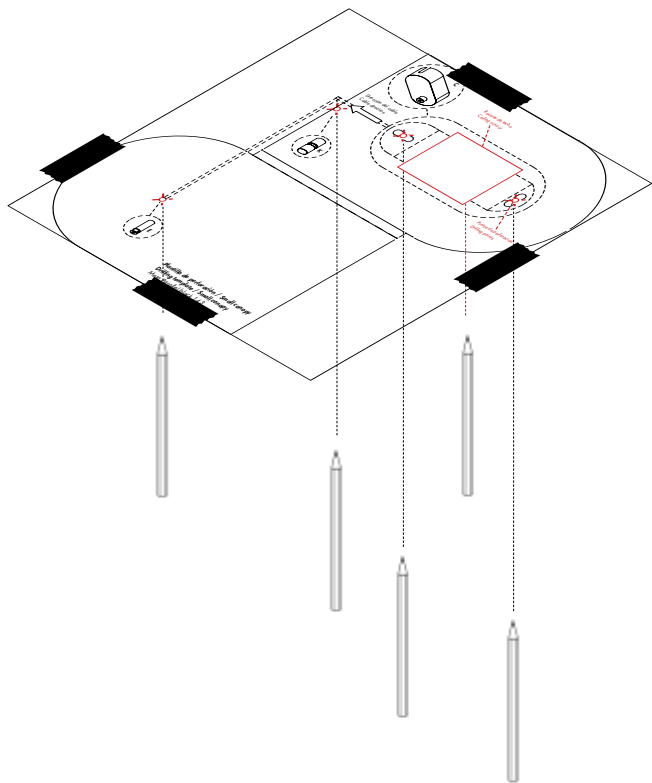



Do not make the rectangular hole bigger as required. Don't take off the template before you finished the perforation.

No hacer la perforación más grande de lo indicado. No retire la plantilla hasta terminar las perforaciones y el corte.

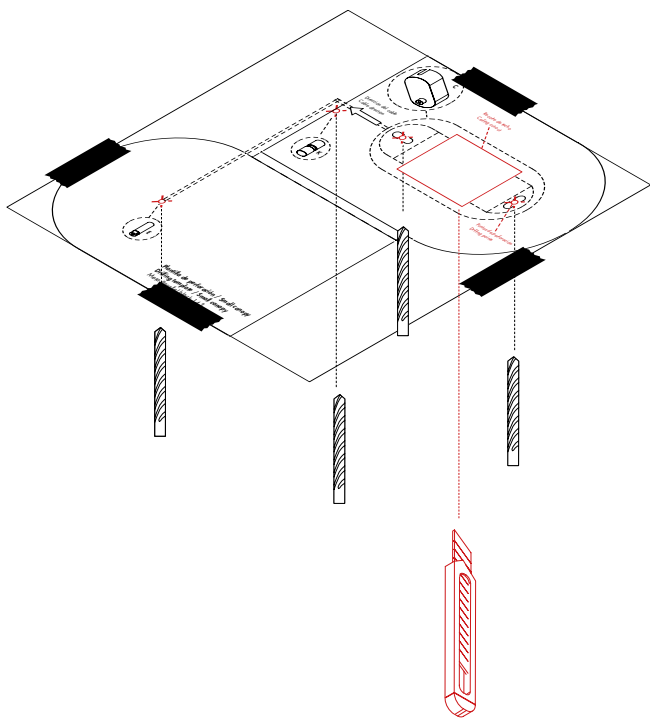

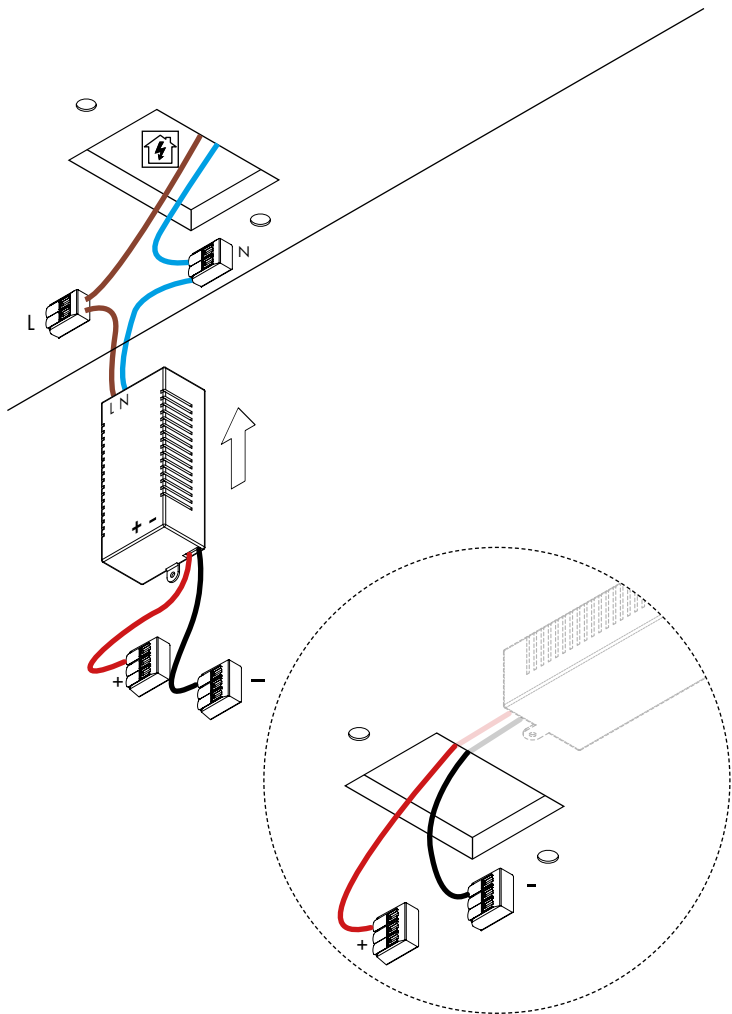

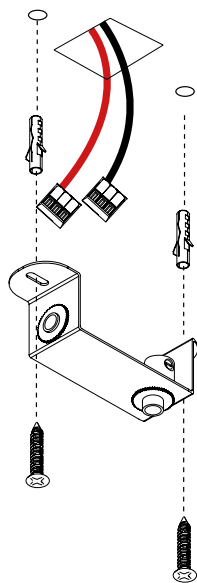

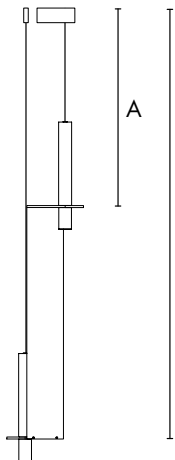

A+70cm (aluminium)
A+56cm (brass)

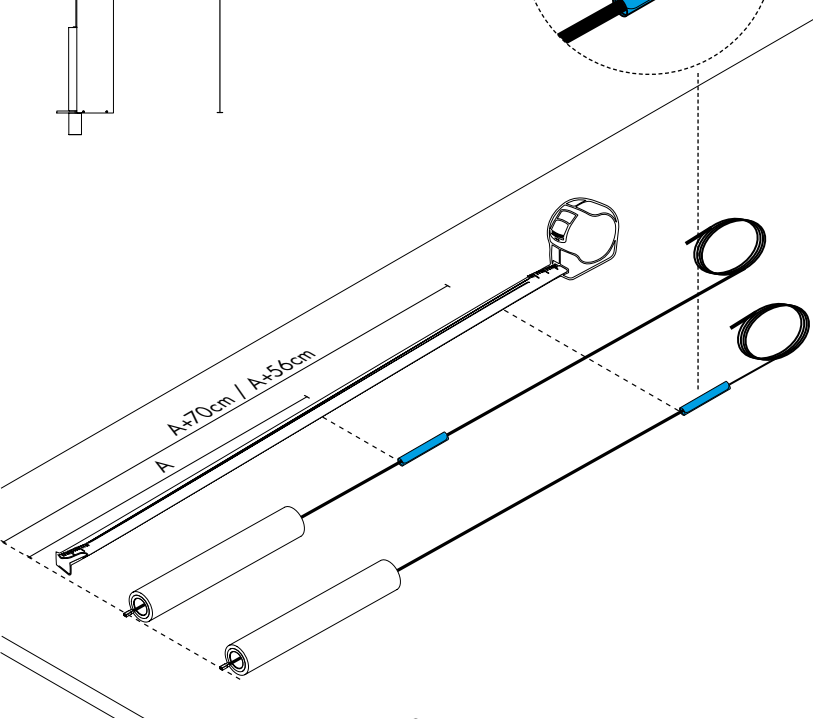
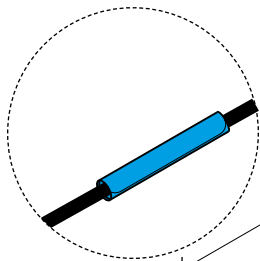

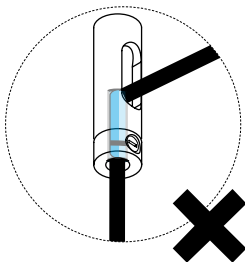
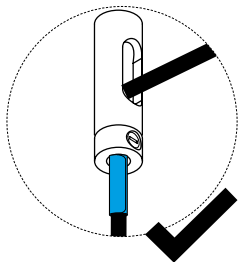
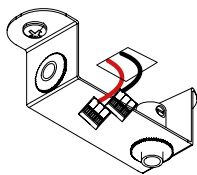
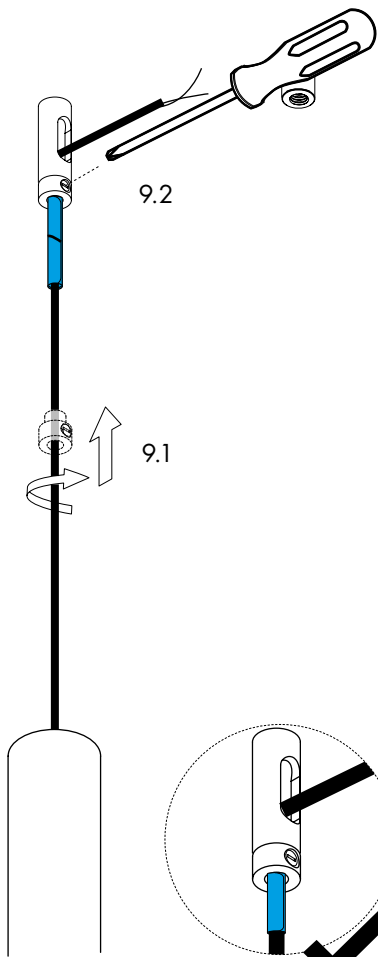

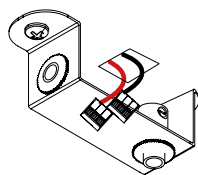
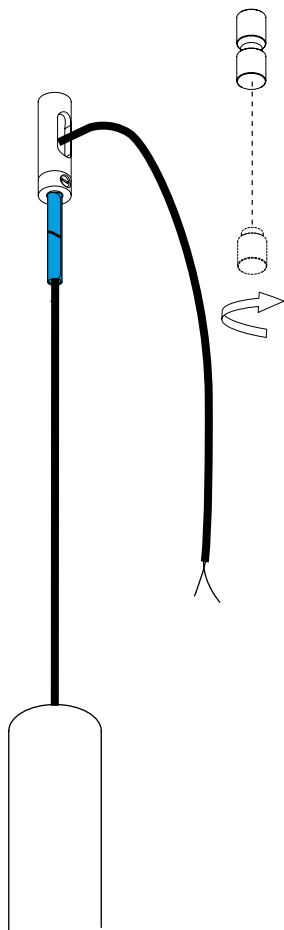

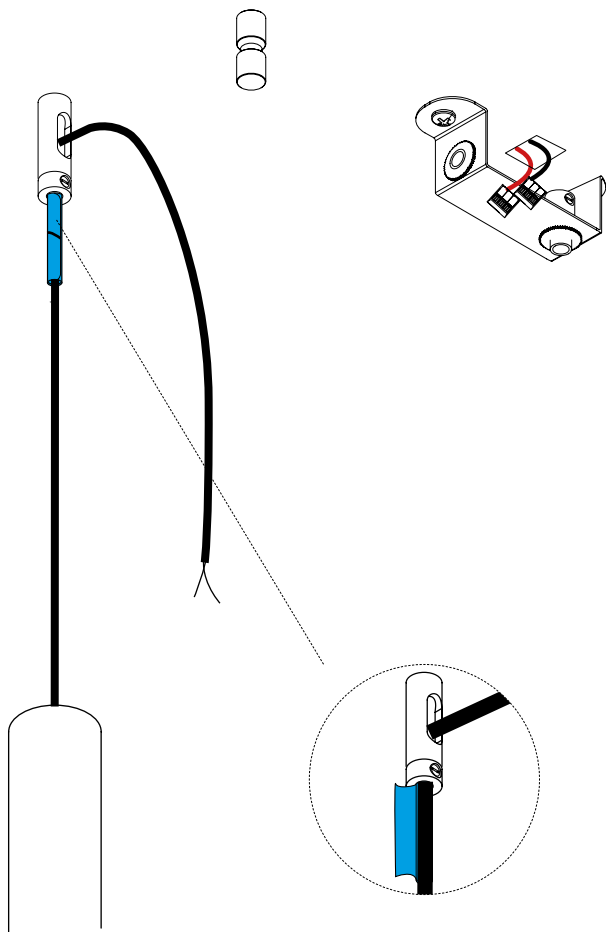

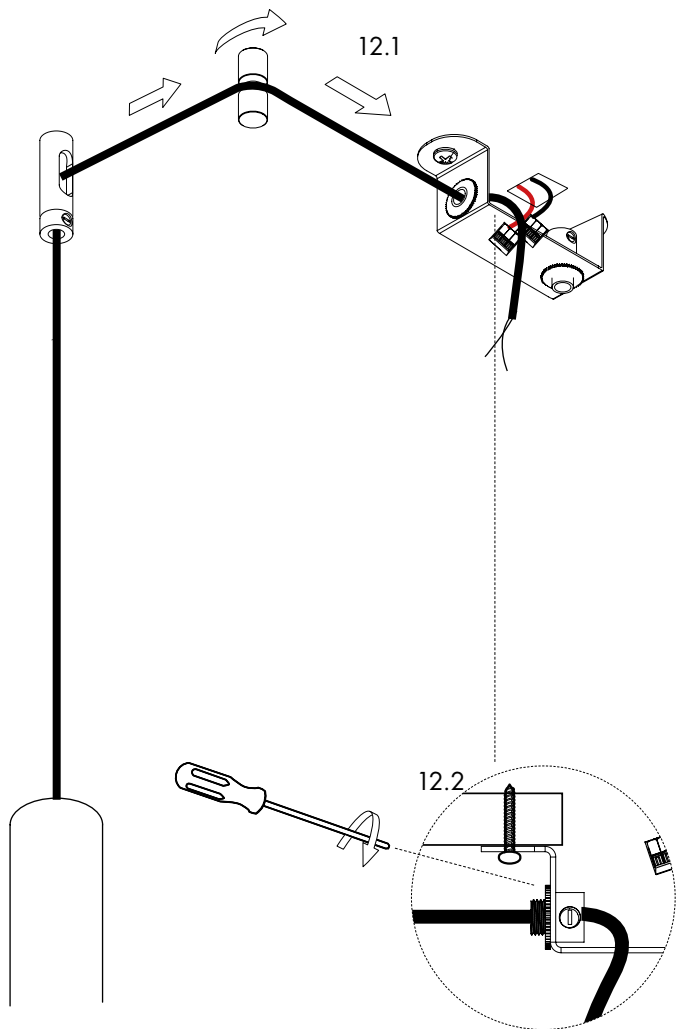

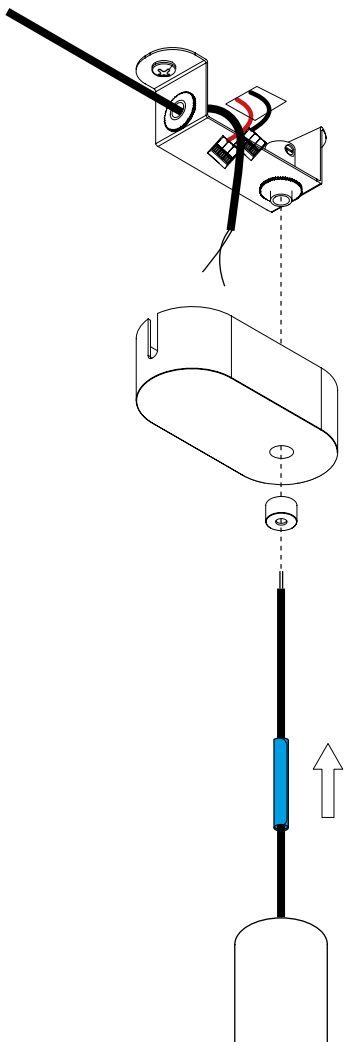



Use the cable clamp for double securing. Place near the cable secure.

Use el candado para cable para doble seguridad. Coloquelo inmediato al pasacable.

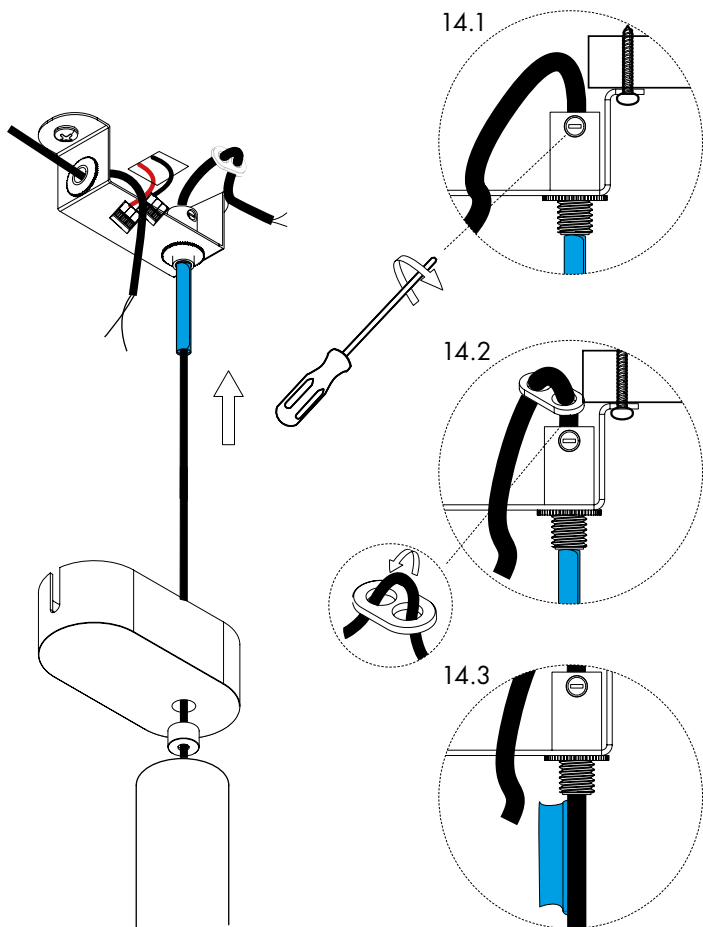

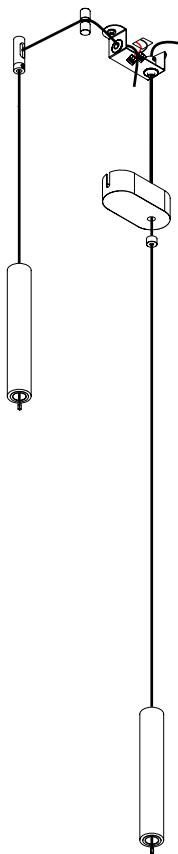

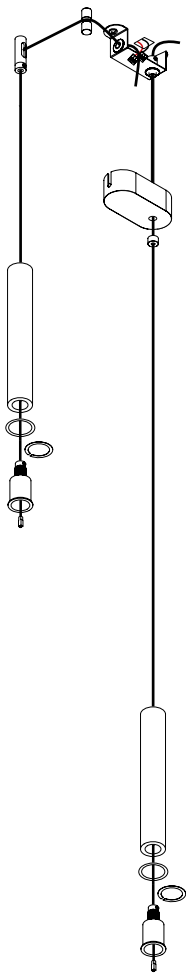

16.1

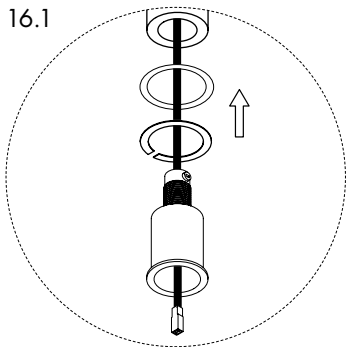

16.2

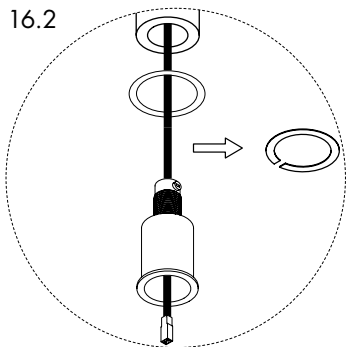

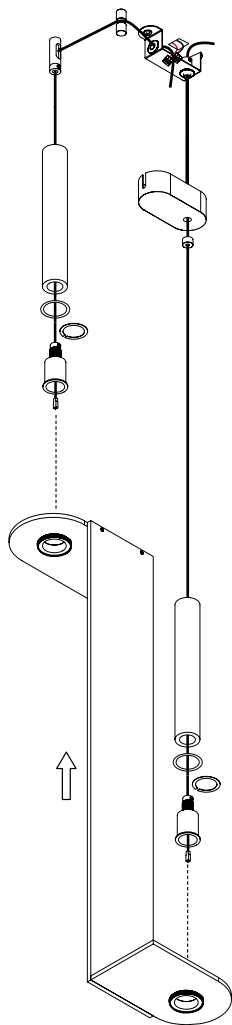

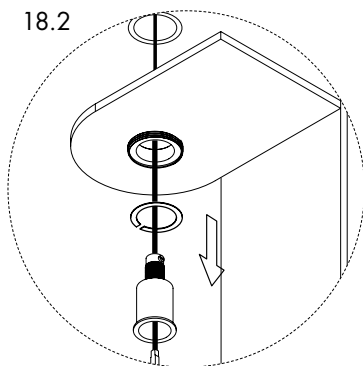
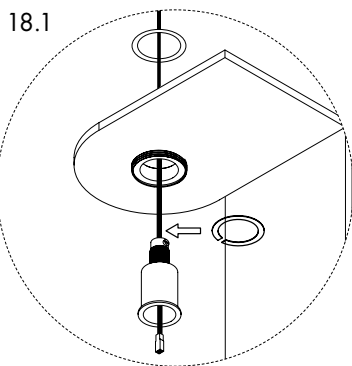
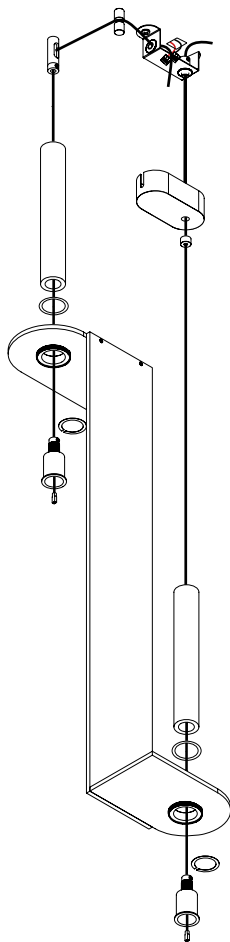

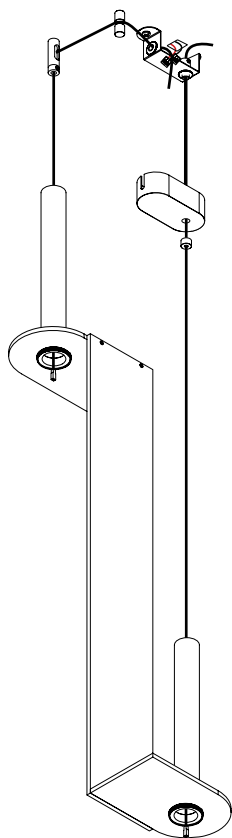



With the use of a leveler make sure the lamp is at a correct level .Adjust the level with the fixing screw 1 and 2.

Con la ayuda de una nivelador, asegura que la pieza este completamente lineal. Ajusta el nivelador con los tornillos plásticos 1 y 2.

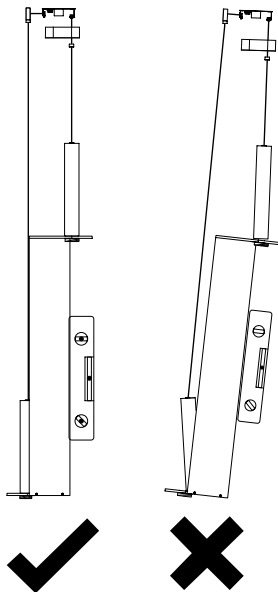

20.1

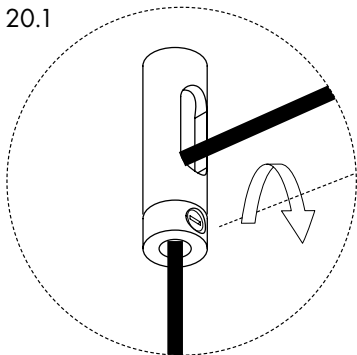

20.2

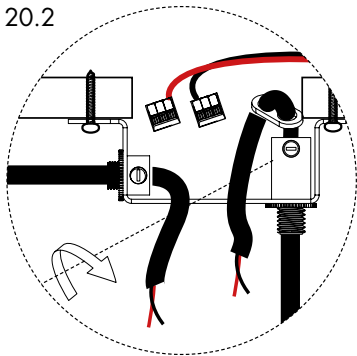



Adjust the level in case you need from 5 to 10mm with the cover technic.

Ajuste el nivel en caso de que requiera de 5 a 10mm con el cubierta.

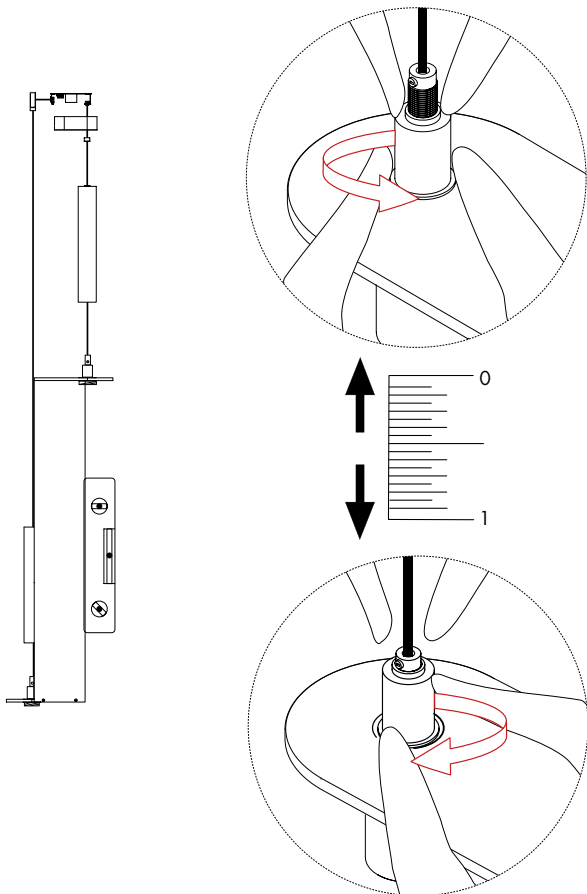



Pay attention of the polarity of the connection. Wrong connection can course damage.

Verificar las polaridades correctas de la conexión, Esto puede causar averías en el producto.

